



**GOVERNMENT OF INDIA
MINISTRY OF RAILWAYS**

**Global Tender for
Consultancy for “Re-design of wheel
for LHB coaches.”**

Estimated Value of the Work/Service:

Rs 1,48,46,607/- (Rupees One Crores, Fourty eight lakhs, fourty six thousand six hundred seven rupees only) inclusive of all taxes.

Tender Document

**Tender No. MC/Wheel design/LHB/2019/01
Opening on 09.05.2019**

Total Number of Pages 37

**RESEARCH DESIGNS AND STANDARDS ORGANISATION
MINISTRY OF RAILWAYS
MANAK NAGAR, LUCKNOW-226011
INDIA**

Preamble

Tender document for work of consultancy for “**Re-design of wheel for LHB coaches** ” has been divided in following parts, as under:-

General Instructions to Tenderers	Page no. 3 to 8
Bid Form-First Sheet	Page no. 9
Bid Form-Second Sheet	Page no. 10 to 14
Special Terms & Conditions/Specifications	Page no. 15 to 20
Bid Form-Third sheet (Schedule of Rates and Approximate Quantities)	Page no. 21
Bid Evaluation-Technical criteria & Illustration	Page no. 22 to 25
Bid Evaluation-Financial criteria & Illustration	Page no. 26 to 28
Annexures	Page no. 29 to 36
GCC for Services (Internet URL Link)	Page no. 37

Total no. of Pages 37

Government of India, Ministry of Railways, Research Designs and Standards Organization reserves the right to accept or summarily reject or cancel any or all bids without assigning any reason.

GENERAL INSTRUCTIONS TO TENDERERS

- 1.1 This Tender Document is non-transferable.
- 1.2 DESCRIPTION & LOCATION OF THE ORGANISATION: Research, Designs & Standards Organisation (RDSO) is situated at Manak Nagar, Lucknow which is the capital city of the State of Uttar Pradesh, India. This Organisation is engaged in Research, design & standardisation of works in various railway disciplines. Carriage Directorate is the part of this organization and is actively engaged in the development of new designs/specifications and upgradation/standardization of the existing designs/specifications of passenger coaches and its sub-systems.
- 1.3 In the bid document 'Railways' shall mean 'Research Design and Standards Organisation' situated at Manak Nagar, Lucknow. Similarly the word 'Manager/Chief Manager' shall mean Jt Director/ Director/Executive Director/Carriage, RDSO or any higher authority of RDSO.
- 1.4 In connection with the work of Consultancy for " Re-design of wheel for LHB coaches ", the Executive Director (Carriage)/RDSO on behalf of the President of India invites open tender for the work of Consultancy for " Re-design of wheel for LHB coaches". The details of works covered under the Scope of Works are given in "Special terms & conditions/specifications" of the tender document. Pre-bid conference shall be held at Carriage Directorate, RDSO/Lucknow on **09.04.2019** for any clarifications required in the bid document by the potential bidders.
- 1.5 In order to avoid summary disqualification in the tender at early stages itself, the following should be kept in view. This list is indicative to assist the bidders in filing their documents correctly for the tender and should not be considered as the only conditions applicable to be qualified for the bid. The bidders are advised to study the complete document carefully to understand all terms and conditions. The submission of the tender shall be deemed to have been done after careful study and examination of the tender document with a full understanding of the implications thereof:
- 1) During bid submission, the tender document is to be signed and stamped by the bidder on each page and the complete document should be submitted along with the bid. The Tender Document can be downloaded from the RDSO's website, <http://www.rdsso.indianrailways.gov.in> , click on **Tender** → **Other Directorate Tender** → **Works** → **Global tender**. Instead of downloading, the tender document can also be purchased in hard copy from Office of Executive Director/Carriage/RDSO, Lucknow, India on payment of requisite fee.
 - 2) The cost of the Tender Document is INR 5,000/- only. Tender Document cost **must** be submitted in the form of a Demand Draft from any nationalized bank or scheduled bank of India. Demand Draft should be in favour of the Executive Director/Finance/RDSO.It is to be submitted in technical bid.
 - 3) The Earnest Money for this tender is INR **2,24,230**/- only. The Earnest Money **must** be submitted only in the form of any one of the following instruments:
Fixed Deposit receipt, Bankers cheques or Demand Draft in favour of the "Executive Director/ Finance, RDSO Lucknow executed by State Bank of India or any of the Nationalized or Scheduled Bank in India. It is to be submitted in technical bid.
Tender Document Cost and Earnest Money submitted in any other form will not be accepted.
 - 4) For financial standing both with reference to **turnover** and **liquidity** , the audited balance sheet and certification from auditor should be ensured.

- 5) Please ensure that the payment received details are positively provided in the form of certificate by the clients in the format Annexure-II without leaving any column and rows while submitting documents against the qualifying condition of **single similar nature work** amounting to 35% of the advertised value of this tender.
- 6) The General Conditions of Contract for Services document of Indian Railways is applicable to this tender. The Special Conditions of Contract stipulated in the Tender Document are in addition to these GCC for Services. At this time, the GCC for services can be downloaded from Indian Railways official website by the following link <http://indianrailways.gov.in/railwayboard> and then following the link 'About Indian Railways' → 'Railway Board Directorates' → 'Transformation Cell' → 'Circulars' → PDF document at Sl No 77.
- 7) The tender document prescribes certain formats for providing information. These format, where ever prescribed in tender document, must be adhered to and no change(s) in the prescribed format should be done by the bidders. Specific attention is drawn to the *Annexure-II (Experience certificate)* of this tender document.
- 8) Deviation from any clause in the tender document is generally not acceptable. If any additional information is to be furnished against any clause(s) stipulated in the tender document then it should be mentioned in a separate sheet giving clear reference to the specific clause(s).
- 9) Please visit the RDSO's website frequently to note any corrigendum or important information uploaded in regard to the tender. The location for such corrigendum or important information shall be same as that for the Tender Document.
- 10) Please read the tender document carefully to understand the documents required to be submitted along with the bid. Please note that after opening of the tender, no further document submission is permitted.

1.6 All information in the tender must be in English. Information in any other language must be accompanied by its authenticated translation in English. In the event of any discrepancy between a tender in a language other than English and its English translation, the English translation will prevail.

1.7 The tender shall be either typewritten or hand written neatly in indelible ink and corrections, if any, attested by the individual signing the tender.

1.8 The cost of tender document is Rs. 5,000/- as stipulated in the tender document payable through separate DD (Demand Draft) in favour of Executive Director/Finance of RDSO and submitted in the technical bid..

1.9 Tenderers should keep their offers valid for period of 90 days from the date of opening of tender.

1.9.1 The tender shall be addressed to Executive Director/Carriage, Annexue-I Building, Carriage Directorate, R.D.S.O., Manak Nagar, Lucknow-226011, in a sealed cover & marked "Offer for Works Tender No. MC/Wheel design/LHB/2019/01.

1.9.2 Tenders sent by registered post shall be with acknowledgement due. The RDSO administration does not take any responsibility on account of delay, loss or non-delivery of the tender document sent by post. The tenders complete in all respects shall reach Executive Director/Carriage, Annexue-I, Carriage

Directorate, RDSO, Lucknow up to 14.00 hrs. on **09.05.2019**. Tenders received after this time & date are liable to be rejected.

- 1.9.3 Tender can also be dropped in the Tender Box painted in Blue Colour and written “Mech. Engg. Dte.” on Tender Box located in RPF post, near TEN office, RDSO, Manak Nagar, Lucknow-226011. The tender box will be sealed at 14.30 hrs. on **09.05.2019**. The tender will be opened on 15.00 hrs. at the location mentioned above on **09.05.2019**. The tenderer(s) or their authorized representatives may choose to witness the opening of tender on **09.05.2019** at the same place. The tender document will not be sold after 12.00 hrs. on **09.05.2019**.
- 1.9.4 The Tenderer shall state in the tender his postal address, fully and clearly. Any communication sent in time to the tenderer by post at his said address shall be deemed to have reached the tenderer duly and in time. Important documents will be sent by Registered post. Scanned copies of important documents in PDF format may also be sent through Email for advance information. For this purpose, the tenderer must also provide official email ID.
- 1.10** All the copies of forms enclosed with tender paper should be duly filled in by the tenderer and attached along with the tender duly signed and Stamped on each page.
- 1.11 Tenderers should submit the following documents for Technical Evaluation of Bid in technical bid.**
- Tenderers shall submit documents which are mandatory according to para number 2.6 of GCC-Service of Indian Railways.
Tendered should also refer to bid evaluation –technical criteria sheet.
- 1.11.1 **Tenderers Credentials:** The bidder(s) shall submit documents related to completed/on-going SIMILAR service contracts during last three financial years and the current financial year along with the details of payments received. Certificate from client firm(s) authorizing payment received, contract-wise for completed/on-going similar service contracts should be submitted along with the bid. Duly filled documents in format in annexure I & annexure II of the tender document along with supporting documents are to be submitted.
- 1.11.2 **Details of Turnover:** Annual & aggregate turn-over in the last three financial years and current financial year up to the date of opening of bid as per audited Balance Sheet certified by chartered accountant.
- 1.11.3 **Details of Liquidity:** The details of liquidity as per audited Balance Sheet and/or banking references certified by chartered accountant with her stamp signature and membership number. The banking reference should be from a scheduled bank in India and it should not be more than three months old as on date of submission of bids.

1.11.4 **Experience of designing or redesigning** of solid forged wheels in last 10 financial years & current financial year for Railway application with speed potential of 200 kmph or more, which has been successfully inducted by any reputed Railway. Experience or performance certificate from the client firm(s) clearly bringing out the details of design/redesign of wheel & its successful induction (clearly mentioning number of year since induction).

1.11.5 Duly filled, stamped & signed tender document except financial bid (bid form-third sheet)

The tenders with incomplete documents shall not be evaluated and shall be summarily rejected.

1.12 The RDSO attaches utmost importance to realistic and timely deliveries and completion of the work. The basic consideration and the essence of the contract shall be the strict adherence to the stipulated time frame and proper quality of maintenance.

1.13 General Instructions

1 **An earnest money** equivalent to **2,24,230/-** only shall accompany the tender. The tender not accompanied by Earnest Money in any one of the approved forms shall be rejected summarily. The Tenderer is required to deposit an Earnest Money of **2,24,230/-** only (Rupees Two Lakhs twenty four thousand two hundred thirty only) in favour of Executive Director/Finance of RDSO.

2 No interest shall be allowed on the earnest money.

3 The Earnest Money is likely to be forfeited if the tenderer withdraws commitments, impairs or derogates from the tender in any respect within the period of his offer.

4 The Earnest Money of unsuccessful tenderers will be returned to them by RDSO after finalisation of bid process.

5 Performance Guarantee (PG) at a rate of 10% of the contractual amount shall be deposited by the successful bidder in the favour of Executive Director/Finance of RDSO. The conditions related to Performance Guarantee shall be governed by para no. 4.11 of GCC-Services.

6 **Minimum Eligibility Criteria:** The Tenderers must submit documentary proof for qualifying against the minimum eligibility criteria as per Para no. 2.6.1 of GCC for Service of Indian Railways. The said para 2.6.1 of GCC-Services is reproduced below (in italicized font) for ready reference:

2.6.1.1 Work Experience: *The bidder should have satisfactorily completed *in the last three previous financial years and the current financial year upto the date of opening of the tender, one similar single service contract **for a minimum of 35% of advertised value of the bid.*

**Completed service contract includes on-going service contract subject to payment of bills amounting to at least 35% of the advertised value of the bid.*

***Similar service contract means any contract that is so specified by the competent authority.*

Similar single service contract for the purpose of this tender shall mean
“Design or redesign of wheel,bogie or coach for Railway application.

or

Design or Redsign of solid wheel & supply of that wheel for railway application.

or

supply of wheel which was designed/redesigned by the bidder in past for railway application.”

Work experience certificate from private individual shall not be accepted. Certificate from public listed company/private company/Trusts having annual turnover of Rs. 500 crore and above subject to the same being issued from their Head Office by a person of the company duly enclosing his authorisation by the Management for issuing such credentials.

[The format for experience certificate is placed as **Annexure-II**]

Note:-

The bidder shall submit details of work executed by them in the prescribed format alongwith bid for the service contract to be considered for qualification of work experience criteria clearly indicating the nature/scope of contract, actual completion cost and actual date of completion for such contract.

[Format prescribed for details of work executed is furnished at **Annexure-I**]

2.6.1.2 Financial Standing: *The Bidders will be qualified only if they have minimum financial capabilities as below:-*

- (i) **T1-Financial Turnover:** *The bidder should have an aggregate financial turnover not less than 1.5 times the advertised bid value during the last three previous financial years and in the current financial year upto the date of opening of the tender. The audited balance sheet reflecting*

financial turnover certified by chartered accountant with her stamp, signature and membership number shall be considered.

- (ii) **T2-Liquidity:** *The bidder should have access to or has available liquid assets, lines of credit and other financial means to meet cash flow that is valued at 5% of the estimated bid value net of applicant's commitments for other contracts. The audited balance sheet and/or banking reference certified by chartered accountant with her stamp, signature and membership number shall be submitted by the bidder along with bid.*

Banking reference should contain in clear terms the amount that bank will be in a position to lend for this work to the applicants/member of the Joint Venture/Consortium. In case the Net Current Assets (as seen from the balance sheets) are negative, only the banking references will be considered. Otherwise the aggregate of the Net Current Assets and submitted banking references will be considered for working out the Liquidity.

The banking reference should be from a Scheduled bank in India and it should not be more than 3 months old as on date of submission of bids.

In case of JV firms overall liquidity of JV firm shall be assessed by arithmetic sum of liquidity of all members of JV.

- 7 The tender, when submitted, shall not constitute an agreement and the tenderer shall have no cause of action or claim against the RDSO. for rejection of his offer. The RDSO shall always be at liberty to reject or accept the offer at its own discretion and any such action will not be called into question and the tenderer shall have no claims in that regard against RDSO.
- 8 Acceptance of tender shall be communicated by FAX/ Telex / Telegram /Express Letter/Email, or a formal letter of Acceptance of Tender. When acceptance is communicated by FAX/ Telex/ Telegram/ Express Letters/Email, the formal letter of acceptance will be sent to the Tenderer as soon as possible. But the FAX/ Telex/ Telegram/Email or express letter should be deemed to conclude the contract.
- 9 The successful tenderer shall be required to execute one or more agreements as necessary with President of India acting through Director General/Executive Director (Carriage)/ RDSO as the case may be for carrying out the work as per agreed conditions.

BID FORM (First sheet)

Name of Work/Service: “Consultancy on Re-design of wheel for LHB coaches ”

Tender no.: MC/Wheel design/LHB/2019/01 dated 19/03/2019

Research, Design and Standards Organisation

To,
The President of India
Acting through the Executive Director/Carriage
Research, Design and Standards Organisation
Ministry of Railways,

1. I/We have read the various conditions to the bid attached hereto and agree to abide by the said conditions. I/We also agree to keep this bid open for acceptance for a period of 90 days from the date fixed for opening the same and in default thereof, I/we will be liable for forfeiture of my/our “Earnest Money”. I/We offer to do the work for **Research, Design and Standards Organisation**, at the rates quoted in the attached schedule and hereby bind myself/ourselves to complete the work in all respects within 07 months from the date of issue of letter of acceptance of the Bid.
2. I/we also hereby agree to abide by the Indian Railways General Conditions of Contract for Services, with all correction slips up-to-date and to carry out the work according the Special conditions of Contract and Specifications of materials and works as laid down by **Research, Design and Standards Organisation** in the annexed Special Conditions/Specifications, Schedule of Rates with all correction slips up-to-date for the present contract.
3. A sum of Rs. **2,24,230/-** (Rupees Two Lakhs twenty four thousand two hundred thirty only) is herewith forwarded as Earnest Money. Full value of the Earnest Money shall stand forfeited without prejudice to any other right or remedies in case my/our Bid is accepted and if:
 - a) I/we do not execute the contract documents within fifteen days after receipt of notice issued by the Railway that such documents are ready; and
 - b) I/we do not commence the work within thirty days after receipt of orders to that effect.
4. I/We am/are a Micro and Small Enterprise registered from (body approved by Ministry of MSME) with registration No. and terminal validity up to for similar service contracts.
5. Until a formal agreement is prepared and executed, acceptance of this Bid shall constitute a binding contract between us subject to modifications, as may be mutually agreed to between us and indicated in the letter of acceptance of my/our offer for this work/service.

Signature of Bidder/s

Date.....

Address.....

BID FORM (Second sheet)

Name of Work/Service: Consultancy on “Re-design of wheel for LHB coaches

1. **Instructions to bidder(s) and Conditions of bid:** The following documents form part of bid/contract;
 - a) Bid forms-First Sheet and Second Sheet
 - b) Special Conditions/Specifications (enclosed)
 - c) Schedule of approximate quantities (enclosed)
 - d) Standard General conditions of Contract and Standard Specifications for Materials and Works of Indian Railways as amended/corrected upto latest Correction Slips, copies of which can be seen or obtained from the office of Executive Director (Carriage)/ RDSO, Lucknow on payment of prescribed charges.
 - e) Schedule of Rates as amended/corrected upto latest Correction Slips, copies of which can be seen or obtained from the office of the Executive Director (Carriage)/ RDSO, Lucknow on payment of prescribed charges.
 - f) All general and detailed drawing pertaining to this work which will be issued by the Manager or her representatives (from time to time) with all changes and modifications.

2. **Drawings for the Work:** The drawings for the work can be seen in the office of the Executive Director (Carriage)/RDSO at any time during the office hours. The drawings are only for the guidance of Bidder(s). Detailed working drawings (if required) based generally on the drawing mentioned above, will be given by the Manager or her representative from time to time. The drawings for the wheel disc (Drg No. LW02115), Wheel and Axle (Drg. No. LW02001) and, Bogie Arrangement (Drg No. LW00010) are attached to this bid Document as Annexure No. IV to VI. These drawings can also be downloaded alongwith the tender documents.

3. The Bidder(s) shall quote her/their rates as a percentage above or below the Schedule of Rates of **Research, Design and Standards Organisation** except where she/they are required to quote item rates and must tender for all the items shown in the Schedule of approximate quantities attached. The quantities shown in the attached schedule are given as a guide and are approximate only and are subject to variation according to the needs of **Research, Design and Standards Organisation**. RDSO does not guarantee work under each item of the Schedule.

4. Tenders containing erasures and/or alterations of tender document are liable to be rejected. Any correction made by tender(s) in her/their entries must be attested by her/them.

5. The works are required to be completed within a period of 07 months from the date of issue of acceptance letter.

6. **Earnest Money:**
 - a) The bid must be accompanied by a sum of Rs. **2,24,230/-** (Rupees Two Lakhs twenty four thousand two hundred thirty only) as earnest money deposited in any

of the forms as specified, failing which the bid will not be considered. However, registered MSEs in terms of Ministry of MSMEs notification No. 503 are exempted from Earnest Money Deposit.

- b) The bidder(s) shall keep the offer open for a minimum period of 90 days from the date of opening of the bid. It is understood that the bid documents have been sold/issued to the bidder(s) and the bidder(s), is /are permitted to bid in consideration of the stipulation on her/their part that after submitting her/their bid subject to the period being extended further, if required by mutual agreement from time to time, she will not resile from her offer or modify the terms and conditions thereof in a manner not acceptable to the Manager/Chief Manager. Should the bidder fail to observe or comply with the foregoing stipulation, the amount deposited as Earnest money for the due performance of the above stipulation, shall be forfeited to the Railway.
 - c) If the bid is accepted, the amount of Earnest Money will be returned to the successful bidder after the submission of the Performance Guarantees as per clause 4.11, for the due and faithful fulfilment of the contract. This amount of EMD shall be forfeited, if the Bidder(s)/Contractor(s) fail to execute the Contract Document within 15 days after receipt of notice issued by Railway that such documents are ready or to commence the work within 30 days (unless otherwise specified) after receipt of the order to that effect.
 - d) Earnest Money of the unsuccessful Bidder(s) will, save as here-in-before provided, be returned to the unsuccessful Bidder(s) within 15 days after finalization of the bid / negotiation, but the Railway shall not be responsible for any loss or depreciation that may happen to the Security for the due performance of the stipulation to keep the offer open for the period specified in the bid documents or to the Earnest Money while in their possession nor be liable to pay interest thereon.
7. **Rights of the Railway to Deal with Tender:** The authority for the acceptance of the tender will rest with the Railway. It shall not be obligatory on the said authority to accept the lowest tender or any other tender and no bidder(s) shall demand any explanation for the cause of rejection of her/their tender nor the Railway to assign reasons for declining to consider or reject any particular tender or tenders.
8. If the bidder(s) deliberately gives/give wrong information in her/their tender or creates/create circumstances for the acceptance of her /their tender, the Railway reserves the right to reject such tender at any stage.
9. If the bidder(s) expire(s) after the submission of her/their tender or after the acceptance of her/their tender, the Railway shall deem such tender cancelled. If a partner of a firm expires after the submission of their tender or after the acceptance of their tender, the Railway shall deem such tender as cancelled, unless the firm retains its character.

10. **Bidder's Credentials:** Bidder shall submit the documents as demanded under Bid Evaluation criteria along with the bid.
11. **For Manual Bidding:**
This bid is called on two packet system basis.
The technical bid and the financial bid must be kept in separate sealed envelopes duly superscripted
“Bid No. MC/Wheel design/LHB/2019/01– Technical bid” and “Bid No. MC/Wheel design/LHB/2019/01– Financial bid”.
- a) Both these envelopes must be kept in a sealed cover, superscripted “Bid No. **MC/Wheel design/LHB/2019/01**” and should be sent by registered post to the address of Executive Director/Carriage, Carriage Directorate, R.D.S.O., Manak Nagar, Lucknow-226011 so as to reach her/their office not later than 14:00 hours on **09.05.2019** or deposited in the special box (Tender Box) allotted for the purpose and located in RPF post, near TEN office, RDSO, Manak Nagar, Lucknow-226011.
 - b) This Special box (Tender Box) will be sealed at 14:30 hours on **09.05.2019**. The Bid will be opened at 15:00 hours on the same day.
 - c) The Bid papers will not be sold after 12:00 hours on **09.05.2019**.
 - d) The financial instruments towards the cost of Tender Document and the Earnest Money Deposit shall be kept in the envelope containing the Technical Bid.
 - e) Bid form (Third sheet) will be filled & tendered in financial bid.
12. Non-compliance with any of the conditions set forth therein above is liable to result in the tender being rejected.
13. **Execution of Contract Documents:** The successful bidder(s) shall be required to execute an agreement with the President of India acting through the Executive Director (Carriage)/RDSO for carrying out the work according to Standard General Conditions of Contract, Special Conditions/ Specifications annexed to the tender and Specification for work and materials of Railway as amended/corrected up to latest Correction slips, mentioned in tender form (first Sheet).
14. **Partnership Deeds, Power of Attorney Etc.:** The bidder shall clearly specify whether the bid is submitted on her own or on behalf of a partnership concern. If the bid is submitted on behalf of a partnership concern, she should submit the certified copy of partnership deed along with the tender and authorization to sign the tender documents on behalf of partnership firm. If these documents are not enclosed along with tender documents the tender will be treated as having been submitted by individual signing the tender documents. The Railway will not be bound by any power of attorney granted by the bidder or by changes in the composition of the firm made subsequent to the execution of the contract. It may, however, recognize such power of attorney and changes after obtaining proper legal advice, the cost of which will be chargeable to the contractor.

15. The bidder whether sole proprietor, a limited company or a partnership firm if they want to act through agent or individual partner(s) should submit along with the tender or at a later stage, a power of attorney duly stamped and authenticated by a Notary Public or by Magistrate in favour of the specific person whether she/they be partner(s) of the firm or any other person specifically authorising her/them to submit the tender, sign the agreement, receive money, witness measurements, sign measurement books, compromise, settle relinquish any claim(s) preferred by the firm and sign “No Claim Certificate” and refer all or any disputes to arbitration.
- 15.1 The bidder shall clearly specify whether the bid is submitted on her own or on behalf of a Partnership Firm/Joint Venture (JV)/Society etc. The bidder(s) who is/are constituents of firm, Company, Association or Society shall enclose self-attested copies of the Constitution of their concern, Partnership Deed and Power of Attorney along with their bid. Bid Documents in such cases shall be signed by such persons as may be legally competent, Association or Society, as the case may be.
- 15.2 The bidder shall give full details of the constitution of the Firm/JV/Company/Society etc. and shall also submit following documents (as applicable), in addition to documents mentioned above:
- a) Sole Proprietorship Firm: The bidder shall submit the notarized copy of the affidavit.
 - b) Partnership Firm: The bidder shall submit self-attested copies of (i) registered/notarized Partnership Deed and (ii) Power of Attorney duly authorizing one or more of the partners of the firm or any other persons(s) authorized by all the partners to act on behalf of the firm and to submit & sign the Bid, sign the agreement, witness measurements, sign Measurement Books, receive payment, make correspondences, compromise/settle/relinquish any claim(s) preferred by the firm, sign ‘No Claim certificate’”, refer all or any dispute to arbitration and to take similar action respect of all Bids/contract OR said Bid/contract.
 - c) Joint Venture (JV): The Bidder shall submit documents as mentioned in Clause 2.4 to GCC.
 - d) Company registered under Companies Act-1956: The Bidder shall submit (i) the copies of MOA (Memorandum of Association) and AOA (Articles of Association) of the Company; and (ii) Power of Attorney duly registered/notarized by the company (backed by the resolution of Board of Directors) in favour of the individual, signing the Bid on behalf of the Company.
 - e) Society: The Bidder shall submit (i) self-attested copy of the Certificate of Registration, (ii) Deed of Formation and (iii) Power of Attorney in favour of the Tender signatory.
- 15.2.1 If it is mentioned in the Bid that it is being submitted on behalf of/by a Sole Proprietorship Firm/Partnership Firm/Joint Venture/Registered Company etc., the afore-mentioned document/s (as applicable) should be enclosed along with Bid. If it is NOT mentioned in the Bid that it is being submitted on behalf of/by a Sole

Proprietorship Firm/Partnership Firms/Joint Venture/registered Company etc., then the Bid shall be treated as having been submitted by the individual who has signed the Bid.

15.2.2 After opening of the Bid, any document pertaining to the Constitution of the Firm/JV/Society etc. shall neither be asked nor be entertained/considered.

15.2.3 A Bid from JV/Consortium/Partnership Firm etc. shall be considered only where permissible as per the Bid/Tender condition.

16. Employment/Partnership etc. of Retired Railway Employees:

- a) Should a bidder be a retired Manager of the Gazetted rank or any other Gazetted officer working before her retirement, whether in the executive or administrative capacity or whether holding a pensionable post or not, in any department of any of the railways owned and administered by the President of India for the time being, or should a bidder being a partnership firm have as one of its partners a retired Manager or retired Gazetted Officer as aforesaid, or should a bidder being an incorporated company have any such retired Manager or retired officer as one of its Directors or should a bidder have in her employment any retired Manager or retired Gazetted Officer as aforesaid, the full information as to the date of retirement of such Manager or Gazetted Officer from the said service and in case where such Manager or Officer had not retired from Government service at least 2 years prior to the date of submission of the tender as to whether permission for tasking such contract, or if the contractor be a partnership firm or an incorporated company, to become a partner or Director as the case may be, or to take the employment under the contractor, has been obtained by the bidder or the Manager or Officer, as the case may be from the President of India or any officer, duly authorised by her in this behalf, shall be clearly stated in writing at the time of submitting the bid. Bids without the information above referred to or a statement to the effect that no such retired Manager or retired Gazetted Officer is so associated with the bidder, as the case may be, shall be rejected.
- b) Should a bidder or contractor being an individual on the list of approved Contractors, have a relative(s) or in the case of partnership firm or company of contractors one or more of her shareholder(s) or a relative(s) of the shareholder(s) employed in gazetted capacity in the any department of the Indian Railway, the authority inviting tenders shall be informed of the fact at the time of submission of tender, failing which the tender may be disqualified/rejected or if such fact subsequently comes to light, the contract may be rescinded in accordance with provision in Clause 7.4 of Standard General Conditions of Contract.

Signature

Designation

Signature of Bidder(s)

Research, Designs & Standards Organisation (RDSO)

Date_____

SPECIAL TERMS & CONDITIONS/SPECIFICATIONS

Name of Work: Consultancy on Re-design of wheel for LHB coaches.

The following special conditions of the contract (SCC) shall be applicable in this contract in addition to the GCC-Services. In the event of any contradiction between these SCC and GCC-Services, the SCC shall prevail.

1. The bids invited against this tender shall be under Two-Packet system and the evaluation of the bids shall be carried out using the Quality and Cost Based System (hereinafter referred as QCBS), evaluation methodology has been explained in Bid Evaluation- Technical criteria & Bid Evaluation- financial criteria with illustration.
2. First the Technical Bids of the bidders shall be opened and evaluated. The financial bids of only those bidders shall be opened who shall attain the minimum qualifying score for their technical bids. The bid with the highest weighted combined score (quality and cost) shall be selected. **The relative weightage of the technical and financial bids in this contract shall be in the ratio of 30:70.**

Similar single service contract for the purpose of this tender shall mean **“Design or redesign of wheel,bogie or coach for Railway application.**

Or

Design or Redsign of solid wheel & supply of that wheel for railway application.

Or

supply of wheel which was designed/redesigned by the bidders in past for railway application”.

3. For proper reflection of annual financial turnover, the audited balance sheet is to be supported along with ‘Income Statement’ by the bidder.
4. In case of foreign bidders, the banking reference from overseas banks shall be acceptable subject to fulfilment of other conditions as prescribed in this bid document.
5. Boarding, lodging and all other related expenses of the consultant and/or his team shall be borne by the consultant.
6. The tenderer/firm should comply with all the following requirements in addition to other qualifying criteria and conditions as stipulated in this bid document, in order to be considered for award of the contract. Necessary documents should be enclosed by the bidder in support thereof.
 - a. The firm should have experience in the field of design of solid forged wheel of Railway Rolling Stock in the past 10 financial years or current financial year .
7. The minimum qualifying score in the technical bid shall be as prescribed in the ‘Bid Evaluation – Technical Criteria’ provided in the bid document.

8. Earnest Money shall be submitted in the form of following instruments:
- a. Fixed Deposit receipt, Bankers cheque or a Demand Draft in favour of the “Executive Director/ Finance, RDSO, Lucknow, India executed by State Bank of India or any of the Nationalized or Scheduled Bank in India.

For avoidance of doubt, Scheduled Bank shall mean a bank as defined under Section 2 (e) of the Reserve Bank of India Act 1934.

9. The bidder(s) shall keep the offer open for a minimum period of 90 days from the date of opening of the bid.
10. The successful bidder shall execute the contract document within 15 days after receipt of notice issued by Railways that such documents are ready.
11. There will not be any advance payment to the contractor/ successful bidder under any name including ‘Mobilization Advance’.
12. The contractor shall commence the services within 30 days after the receipt by her in writing acceptance of offer effect from the Manager /Director//Director(RDSO).

13. Payment terms:

- a. The contractor shall raise bill for payment after completion of all the items of the contract as mentioned in the schedule of rate (Bid Form - Third Sheet). The payment shall be done for the total payable amount for the items, after completion of all the items of work and after certification of the Manager/Director/Jt Director or her representative to that effect.
- b. The final bill payment shall be made in accordance with the GCC-Services and after submission of a Bank Guarantee of 10 % of the total value of the contract for maintenance period of 3 years in terms of scope of work.
- i) The Bank Guarantee for maintenance period should remain valid for the period of 3 years (period required for service trial of redesigned wheel) plus 60 days from the date of completion of the contract. It will be forfeited, if contractor does not honour commitment during maintenance period after completion of the service. A maintenance period of 3 years will start after completion of the contract as per this scope of work. Minor changes required in new design/redesign of the wheel might be required to be done by the contractor during maintenance period, based on feedback from its operation in service.
- c. The bank guarantee for maintenance period shall be released after satisfactory completion of maintenance period.
- d. The Bank Guarantee for maintenance period shall be in any form as applicable for Performance Bank Guarantee mentioned in this contract. No interest shall be payable by RDSO to the contractor against the Bank Guarantee for maintenance period as stipulated hereinabove.
- e. The contract price will be normally paid in the currency or currencies in which the price is stated in the successful bid. However, Indian Railways reserves the right to effect payment of equivalent amount in the currency or currencies of the country of origin of the work/goods/services in case the price is stated in

other currencies. The equivalent amount will be calculated on the basis of exchange rate prevailing on the date of payment.

- f. Payments shall be made in INR to Indian firms or, in case of foreign firms, through ECS/EFT or Letter of Credit (LC). In case of payment through LC, all charges including the confirmation charges of LC, levied by foreign banks shall be borne by the contractor.
- g. All taxes, duties etc leviable on this contract and payable to Government of India as per applicable tax laws shall be deducted by the Indian Railways from the Contractor's Bills before making any payment.
- h. Withholding taxes may need to be paid by an overseas firm if it is a successful bidder as per Government of India taxation laws.
- i. Indian Railways shall not be liable to pay any taxes or duties paid by the contractor due to misclassification.
- j. **Statutory Variation Clause:** Any statutory variation in taxes or duties arising in future is liable to be admissible only within the original completion period of the contract subject to production of documentary evidence and related government notifications, further subject to indication of the same in firm's offer and contract. The following shall be applicable:
 - i. Reduction in price of the goods and services being supplied by the contractor to Indian Railways, resulting from any reduction or remission of taxes and duties shall be passed onto Indian Railways by the contractor irrespective of the original completion period of the contract.
 - ii. Any increase in taxes and duties beyond the original completion period of the contract shall be borne by the contractor.
- k. Where the bidder has quoted all-inclusive price without mentioning the taxes at present or in future and has also not quoted with Statutory Variation Clause, the contractor shall have to bear the future variations in all such cases.
- l. Tenderer to give consent in a mandate form (Annexure-III) for receipt of payment through ECS /EFT. Tenderer to provide the details of bank account in line with RBI guidelines for the same. These details will include bank name, branch name and address, account type, bank account number and bank & branch code as appearing on MICR cheque by bank. Tenderer to attach certificate from their bank certifying the correctness of all such information.
- m. In case of non-payment through ECS/EFT or where ECS/EFT facility is not available, payment will be released through cheque. Payment by irrevocable letter of credit can also be made. However, in such cases, the contractor has to give a notice of one month before submitting request for payment.
- n. **Paying Authority:** Payment for all items of the contract will be made by Executive Director/Finance, RDSO, Manak Nagar, Lucknow-226011.

14. **Price Variation Clause** is not applicable to this contract.

15. **Insurance:** Insurance cover for all stores including material, instruments and documents in transit shall be provided for by the contractor.

16. **Penalty:** A penalty of maximum 10% of the total value of the contract may be imposed in case of unsatisfactory performance of the contractor. The decision of the

Manager/Chief Manager/Executive Director regarding performance of the contractor shall be final and binding in this regard.

17. Settlement of disputes including arbitration between the contractor and Indian Railways, if any, and not provided for in the SCC shall be by way of the GCC-Services.

18. Price Basis:

- i. Tenderers are required to quote on firm price basis.
- ii. The prices quoted must include all charges e.g. Taxes (withholding Tax, GST etc.), levies, duties, cess, packing, forwarding and delivery charge etc. as applicable in India.
- iii. The prices should be stated only in one currency and should be either in the currency of the bidder's country or in US dollar or in any other currency widely used in International trade. Tenderers belonging to countries with which Government of India have Rupee Payment Agreements should quote the entire bid price in Indian Rupees.

19. Scope of Work:

The scope of work shall be as under:

New wheel will be redesigned for existing FIAT bogie (drawing No.LW00010) of LHB coaches (drawing No.LE90009), suitable for carrying wheel set of 18t axle load provided with disc brakes for maximum speed of 200 kmph + 10%. LHB coaches of Indian Railways are fitted with FIAT Bogies for 1676 mm Track Gauge. The scope shall include:

- 1) Study of design, drawings, & specification of existing wheel (drawing No. LW02115) in reference to loading and operating conditions of Indian Railway network may be done for designing/redesigning of new wheel.
 - a) Testing of samples of upto 02 nos. of existing unserviceable LHB wheels may be done, if required by the designer. Tenderer can ask for samples of existing unserviceable LHB wheels and may collect the same at their own logistics and transportation cost. Cost of these wheels will not be claimed by Indian Railways as these will be consumed in destructive testing.
 - b) Reports of study and analysis of design, drawing, & specification of existing wheel and test reports of all kinds of test conducted on existing LHB wheel samples collected by the designer shall be submitted.
 - c) It is suggested that for better appreciation of service, maintenance, & operation conditions, Indian Railway workshop & other required installations may be visited by the designer.
- 2) DESIGNED/REDESIGNED new wheel should meet following functional, interchangeability & other requirements :
 - i) New tread diameter is 915 mm.
 - ii) Tread profile shall be as per RDSO drawing No. Sketch-91146.

- iii) New wheel must be designed in such a way as to ensure that it is accommodated in the envelope of existing bogie drawing while maintaining necessary clearances.
- iv) Dimensions (diameter, hub length) and finish of bore shall be as per drawing No. LW02115.
- v) The condemning diameter shall be 845 mm.
- vi) The condemning wear groove should be provided.
- vii) The geometry of the area for wheel clamping will be such, as it can be re-profiled on existing re-profiling machines.
- viii) The position and shape of the hole and groove for displacement under oil pressure will be provided.
- ix) LHB coaches are provided with axle mounted disc brake system with 02 brake disc on each axle and brake cylinder pressure of 3 kg/cm². Further details required by the tenderer about braking system will be provided.
- x) New design/re-design of wheel will be for axle with static axle load capacity of 18t, same as in the present wheel design.
- xi) Description of the lines: geometric quality of the tracks, curve parameters, maximum speeds etc., if required by the tenderer, will be provided.
- xii) A clear identification mark for new design/redesign wheel will be ensured, so that it can be differentiated from existing design wheels on the field. Identification marks shall be on outer face of wheel rim below condemning groove, which is visible from outer side in fitted condition.
- xiii) Service life of approx. 4 years should be achieved on Indian Railways conditions.
- xiv) Acoustic performance of new design/redesign wheel should not be worse by more than 10% of acoustic performance of present wheel (drawing No. LW02115) in similar conditions. New design/redesign wheel will be low noise-low weight wheel. Maximum weight will be up to 370 kg. Lighter & more silent wheel design is preferred.
- xv) New design/redesign wheel should address the problem of wheel shelling. Performance, in terms of shelling, of new design/re-design wheel should be better than that of existing wheel in different service & operating conditions in Indian Railways. Improvement brought out through improved chemistry will be validated in terms of shelling reduction & increase in service life by calculations, explanations & other methods.
- xvi) New design/re-design wheel should be in compliance of EN 13262, UIC-510-5 and 13979-1.
- xvii) RDSO Specification IRS R-19/93 part II (rev. 4) with corrigendum number 1 of August'2015 is used for present wheel for FIAT bogie .The material specification of wheels for Indian Railway was finalized considering various aspects including wear characteristics of wheels and rails. The specification is attached for guidance. Upper hardness limit of rim will preferably be as per IRS R-19/93 Part II (Rev.4).
- xviii) Wheels in Indian Railways are maintained in terms of LHB coach maintenance manual issued by CAMTECH, & IRCA Part IV.
- xix) As coaches on Indian Railways are operated in hot & humid climate, wheels are prone to corrosion. Suitable provision of lasting protection against corrosion will be included in the specification. It should include protection to be provided during/after manufacturing as well as during maintenance/operation.

- xx) Material chemistry of redesigned wheel will be such that it does not increase prices of wheels prohibitively during procurement. The chemistry should result in improvement in terms of wheel shelling performance.
- 3) The designer of the designed/re-designed new wheel shall supply documentation comprising:
- ii) Specification, it should include the description of the fabrication process (forging, rolling, heat treatment etc).
 - iii) The definition of the wheel geometry (drawing).
 - iv) Fabrication parameters
 - a) Geometrical tolerances.
 - b) Surface finishes.
 - c) Steel grade.
 - v) Final design/redesign shall be validated for compliance to the mentioned standards & other requirements in scope of work . All the documents & reports for establishing the validation will be submitted. FEM calculations will be done as per relevant EN/UIC standards. Thermo mechanical & mechanical behaviour comparisons of new design/re-design with reference to present wheel design (drawing No. LW02115 with 14 mm minimum web thickness near rim) will also be submitted.
 - vi) RDSO shall give feedback on these submitted documents. After feedback & approval from RDSO, final documents for specification, drawing, fabrication parameters & validation shall be submitted.
 - vii) Design of the redesigned wheel will be transferred to Indian Railways. Design of the wheel will become property of Indian Railways after full payment and completion of the consultancy work.

BID FORM (Third Sheet)

Name of Work/Service: Consultancy for “Re-design of wheel for LHB coaches”

SCHEDULE OF RATES AND QUANTITIES

S.No	Item No.	Description of item of Work/ Service	Approximate Quantity	Unit	Basic rates per unit in Figures and Words	Taxes and rate of taxation, if any	Total rates per unit in Figures and words	Amount with currency
A	B	C	D	E	F	G	H= F+G	I= E*H
1	1	Consultancy for “Re-design of wheel for LHB coaches” as per scope of work	1	1				

The quantities shown in above Schedule are approximate and are as a guide to give the Bidder(s) an idea of quantum of work involved. The Railway reserves the right to increase/ decrease and/or delete or include any of the quantities given above and no extra rate will be allowed on this account.

I/We undertake to do the work at ----- % above/below the schedule of rates of the Railway at the rates quoted above for each item (wherever percentage rates are not invited kindly see note given below).

Dated _____

Signature of the Bidder(s)

Note: Columns A to E shall be filled by the office of the Authority inviting Bid. Columns F to I shall be filled by the Bidders.

Bid Evaluation- Technical Criteria

The following criteria along with minimum eligibility criteria mentioned in GCC for service contracts shall be applied for evaluation of technical bids of the Bidder(s). A minimum of 35 marks is essential for opening of Price bid.

Sl. No.	Weightage	Technical Criteria	Documentation required	Scoring method
1.	10%	<p>Details of pervious work done The bidder(s) shall submit documents related to completed/on-going SIMILAR service contracts during last three financial years and the current financial years along with the details of payments received. Such previous experience shall be classified as follows: Payment received:</p> <ol style="list-style-type: none"> a. More than or equal to 80% b. More than or equal to 60% c. More than or equal to 35% <p>(Bidder(s) without a single work of similar nature or payment received less than 35% of the advertised value of the bid are not eligible)</p>	<p>Certificate from client firm(s) authorizing payment received, contract-wise for completed/or-going similar contracts defined in the tender booklet.</p>	<p>Scoring: Maximum marks under this head is 100.</p> <ol style="list-style-type: none"> a. 100 marks if the bidder has completed received payment as under: From 1 project, payment more than or equal to 80% of the advertised bid value From 2 projects, payment more than or equal to 50% of the advertised bid value from each b. 50 marks if the bidder has completed or received payment as under: From 1 project, payment more than or equal to 60% of the advertised bid value From 2 projects, payment more than or equal to 40% of the advertised bid value from each c. 20 marks if the bidder has completed or received payment as under: From 1 project, payment more than or equal to 35% of the advertised bid value
2.	10%	<p>Details of Turnover Aggregate financial turn-over during the last three financial years and current financial year up to the date of opening of bid.</p> <p>(Bidder(s) whose aggregate</p>	<p>Audited balance sheets and Income statements certified by CA</p>	<p>Scoring: Maximum marks under this head is 100.</p> <ol style="list-style-type: none"> a. 100 marks if the bidder has aggregate turnover more than 5 times the advertised bid value of the work. b. 50 marks if the bidder has aggregate turnover more than or equal to 1.5 times to 5 times the advertised bid value of the work.

		financial turn-over is less than 1.5 times the advertised bid value of the work are not eligible)		
3.	80%	<p>Experience of designing or redesigning of solid forged wheels in last 10 financial years & current financial year for Railway application with speed potential of 200 kmph or more, which has been successfully inducted by any reputed Railway.</p> <p>This shall be assessed on the basis of total number of designed or redesigned wheels & their successful implementation in any reputed Railway in last 10 financial years & current financial year. Successful implementation of designed or redesigned wheel will mean successful operation of wheels of such design/redesign for atleast 2 years in any reputed railway system without any complaint for its operation..</p>	<p>Experience or performance certificate from the client firm(s) clearly bringing out the details of design/redesign of wheel & its successful induction (clearly mentioning number of year since induction).</p>	<p>Scoring: Maximum marks under this head is 100.</p> <p>a. 100 marks if the bidder has designed or redesigned more than 03 such wheels..</p> <p>b. 70 marks if the bidder has designed or redesigned 02 or 03 such wheels.</p> <p>c. 35 marks if the bidder has designed or redesigned 01 such wheel.</p> <p>d. 0 marks if no design/redesign of such wheel in last 10 financial years & current financial year.</p>

NOTE:

1. The total marks received by a bidder under each head above shall be multiplied with the weightage indicated against each and then added up to determine total marks for that bidder.
2. The minimum qualifying marks in the technical evaluation bid of any bidder after considering weightage shall be 35 out of maximum 100.
3. In case, currency in other than Indian National Rupee is there in documentation submitted for technical criteria, the amount in Rupees for the purpose of evaluation shall be arrived at by considering the B.C. (Base currency) selling exchange rate established by the State Bank of India prevailing as on the date of tender opening.

Illustration sheet for Evaluation of Technical Bids

Bids will be evaluated by the method of Quality and Cost Based System (QCBS) mentioned in para 2.6 (C) of GCC-Services. The bid document specifies the minimum qualifying score for the quality of technical bid and also the relative weightages to be given for quality and cost at the ratio of 30:70 in this contract.

- **Evaluation of Technical Bid accordingly sheet name “Bid Evaluation-Technical Criteria” attached with the Tender document.**

S. No	Name of Bidders	Technical Criteria	weightage % (S)	Maximum Score	Obtained Technical Score by the bidder (T)	Quality score of the bidder Quality score P= (S x T)/100
1.	M/s “A”	Details of previous work done as mentioned in “Bid Evaluation-Technical Criteria”	10%	100	100	10
		Detail of turnover	10%	100	100	10
		Experience in design/redesign of solid forged wheels	80%	100	35	28
		Total Score obtained by the bidder “A”				
2.	M/s “B”	Details of previous work done as mentioned in “Bid Evaluation-Technical Criteria”	10%	100	50	5
		Detail of turnover	10%	100	100	10
		Experience in design/redesign of solid forged wheels	80%	100	70	56
		Total Score obtained by the bidder “B”				
S. No	Name of Bidders	Technical Criteria	weightage % (S)	Maximum Score	Obtained Technical Score by the bidder (Q)	Quality score of the bidder Quality score = (S x Q)/100

3.	M/s “C”	Details of previous work done as mentioned in “Bid Evaluation-Technical Criteria”	10%	100	100	10
		Detail of turnover	10%	100	50	5
		Experience in design/redesign of solid forged wheels	80%	100	100	80
Total Score obtained by the bidder “C”					95	

T is Score given out of 100 for Technical criteria

S is Quality weighting (%)

The weightage of the Technical Bid is 30% in the overall evaluation as mentioned in special terms and conditions of bid documents.

Marks for technical bid in overall evaluation (Q) = (Obtained score x Decided ratio of technical)/100

$$M/s \text{ “A”} = (48 \times 30)/100 = 14.4$$

$$M/s \text{ “B”} = (71 \times 30)/100 = 21.3$$

$$M/s \text{ “C”} = (95 \times 30)/100 = 28.5$$

Evaluation of Financial Bid: According to QCBS method, the weightage of Financial Bid is 70%.

Bid Evaluation- Financial Criteria

The following criteria shall be applied for evaluation of Financial Bid of the Bidder(s).

- Total price quoted by the bidder inclusive of all taxes shall be arrived at as per her bid.
- The financial bid evaluation shall have two parts for marking/evaluation. Part 1 will be out of 80 marks and part 2 will be out of 20 marks. Thus the total marking will be out of 100 marks for Financial Bid.
- The marks obtained by each bidder in part 1 and 2 will be added to arrive at total marks out of 100 in Financial Bid evaluation.

S.N.	Financial Criteria	Documentation Required	Scoring method
1.	In part 1, the lowest bid shall be given 80 marks. The other bids shall be given proportionately lower marks according to their total bid value.	Filled up "BID FORM (Third Sheet)" Schedule of Rates and Approximate Quantities	Scoring: Maximum marks under this head is 80.
2.	In part 2, the marking will be out of 20 marks: With more marks being given to bids which are more below the estimated value of the tender.		Scoring: Maximum marks under this head is 20. <ul style="list-style-type: none"> • 0 marks if bid value is more than estimated value • 5 marks if bid value is from 95% up to 100% of the estimated value. • 10 marks if bid value is from 90% up to less than 95% of the estimated value. • 15 marks if bid value is from 80% up to less than 90% of the estimated value. • 20 marks if bid value is less than 80% of the estimated value.

Note: In case the rates are quoted in currency other than Indian Rupee, the amount in Rupees for the purpose of evaluation shall be arrived at by considering the B.C. (Base currency) selling exchange rate established by the State Bank of India prevailing as on the date of Tender opening.

Illustration sheet for Evaluation of Financial Bid

- **Evaluation of Financial Bid accordingly sheet name “Bid Evaluation-Financial Criteria” attached with the Tender document .Estimated cost has been assumed as Rupee 20 crores for illustration purpose only.**

S.No	Name of Bidders	Part 1 Max marks 80	Part 2 Max. marks 20	Max marks is 100 (Part 1 + Part 2)
1.	M/s “A”	80 mark obtained L1 as per lowest quoted rate i.e. 18 crore	Bid value as percentage of estimate value = 90% Therefore, marks = 10	80 + 10 = 90
2.	M/s “B”	i.e. $(18/19.5)*80 = 73.8$ L2 as per quoted rate i.e. 19.5 crore	Bid value as percentage of estimate value = 97.5% Therefore, marks = 5	73.8 + 5 = 78.8
3.	M/s “C”	i.e. $(18/21)*80 = 68.5$ L3 as per quoted rate i.e. 21 crore	Bid value as percentage of estimate value = 110% Therefore, marks = 0	68.5 + 0 = 68.5

According to QCBS method, the weightage of Financial Bid is 70 % as per decided ratio of evaluation of bid.

Marks for financial bid in overall evaluation C = (Mark obtained in financial bid x Decided weightage of financial bid i.e.70)/100

M/s A has obtained = $(90/100)*70 = 63$

M/s B has obtained = $(78.8/100)*70 = 55.16$

M/s C has obtained = $(68.5/100)*70 = 47.95$

Illustration sheet for overall Evaluation of bidders as per QCBS

Name of Firms	Marks for technical bid (Q) i.e i.e. Maximum Marks=30	(C) maximum financial bid Maximum Marks =70	Maximum Marks =100 (Weight combined score)
M/s A	14.4	63	77.40
M/s B	21.3	55.16	76.46
M/s C	28.5	47.95	76.45

The bidder who obtains maximum weighted combined score (Q+C) in overall evaluation as per QCBS will be the successful bidder. In this case of illustration, M/S A is the successful bidder.

If there is tie between two or more bidders in maximum (Q+C) score, bidder with higher score in technical bid (Q) will be the successful bidder. If those bidders have tie in technical bid (Q) as well, bidder with higher score in criteria at sl no 3 of Bid Evaluation-Technical Criteria sheet (**Experience of designing or redesigning** of solid forged wheels in last 10 financial years & current financial year for Railway application with speed potential of 200 kmph or more) will be the successful bidder.

Format for Details of the Previous Works/Services by the Bidder

Sl No	Name of the Work	Brief Scope of Work <i>(Indicate activities covered under the scope, especially those which relate to technical evaluation of your bid)</i>	Agreement Number and Date	Details of Firm/Client for whom work was done	Experience certificate from Firm/Client enclosed? (Yes/No)	Value of Work as per Agreement indicating currency unit (in figure and words)	Due date of completion (in case of continuing work)/ Actual completion date	Amount received against the work from Firm/Client indicating currency unit (in figure and words)	Financial Year* in which the payment was received from Firm/Client
1.									
2.									
3.									
4.									
5.									

*Financial Year is taken from 1st April of a year upto 31st March of succeeding Year e.g. the period of 1st April 2015 to 31st March 2016 is taken as Financial Year 2015-2016.

In case payment for a single work has been received in different financial years, indicate payment received against each financial year for that work.

Signature of Bidder

On the Issuing Firm/Client's Official Letterhead

Reference No: _____

Date of Issue: _____

Work Experience Certificate

It is certified that M/s bidder/executing agency's name having their offices at _____ have completed/in process of completing* the following work/services for Certificate Issuing Firm's Name and address. *(Strike out whichever is not applicable)

Sl No	Item	Details
1.	Name of Work/Service	
2.	Agreement Number with date and, name & address of agency to whom the work awarded	
3.	Brief scope of the work/service.	
4.	Agreement Value indicating currency unit (in words and figures)	
5.	Due date of completion as per agreement	
6.	Number of extensions granted	
7.	Actual Date of completion of work/service (if completed)	
8.	Total Value of Payment released to the executing agency against the agreement indicating currency unit (in words and figures)	
9.	Remarks about quality of performance of the executing agency under the agreement	

It is also certified that I, Mr/Mrs/Ms working as _____ in the Issuing Firm's Name, am authorized to issue this certificate to bidder/executing agency's name on behalf of Issuing Firm's name having offices located at address of issuing firm.

**Affix Office Seal/
Stamp here**

(Signature)
Full Name
Designation
Contact details

MANDATE FORM

Electronic Clearing Service (Credit Clearing)/ Real Time Gross Settlement (RTGS) facility
for receiving payments.

A. Details of Account Holder:-

Name of Account Holder	
Complete Contact Address	
Telephone Number/FAX/E-mail	

B. Bank Account Details:-

Bank Name	
Branch Name with complete address, Telephone no. and E-mail	
Whether the Branch is computerized?	
Whether the branch is RTGS enabled? If yes then what is the Branch's IFSC Code	
Is the Branch also NEFT enabled?	
Type of Bank Account (SB/Current/Cash credit)	
Complete Bank Account No. (Latest)	
MICR Code of Bank	

Date of effect:-

I hereby declare that the particulars given above are correct and complete. If the transaction is delayed or not effected at all for reasons of incomplete or incorrect information, I would not hold the use Institution responsible. I have read the option invitation letter and agree to discharge responsibility expected of me as a participant under the Scheme.

Signature of Customer

Date

Certified that the particulars furnished above are correct as per our records.

(Bank's Stamp)

Date:

Signature of Customer

1. Please attach a photocopy of cheque along with the verification obtained from the bank.
2. In case your Bank Branch is presently not "RTGS enabled", then upon its up gradation to "RTGS Enabled" branch, please submit the information again in the above proforma to the Department at earliest.

NOTE:- Refund of Security Deposit/Hire Charges

Due to operation of E-payment w. e. f. 01/04/2012 the Mandate form may please be submitted, duly verified by the bank, to this office for claiming Refund of Security Deposit/ Hire Charges along with a photocopy of blank Cheque.

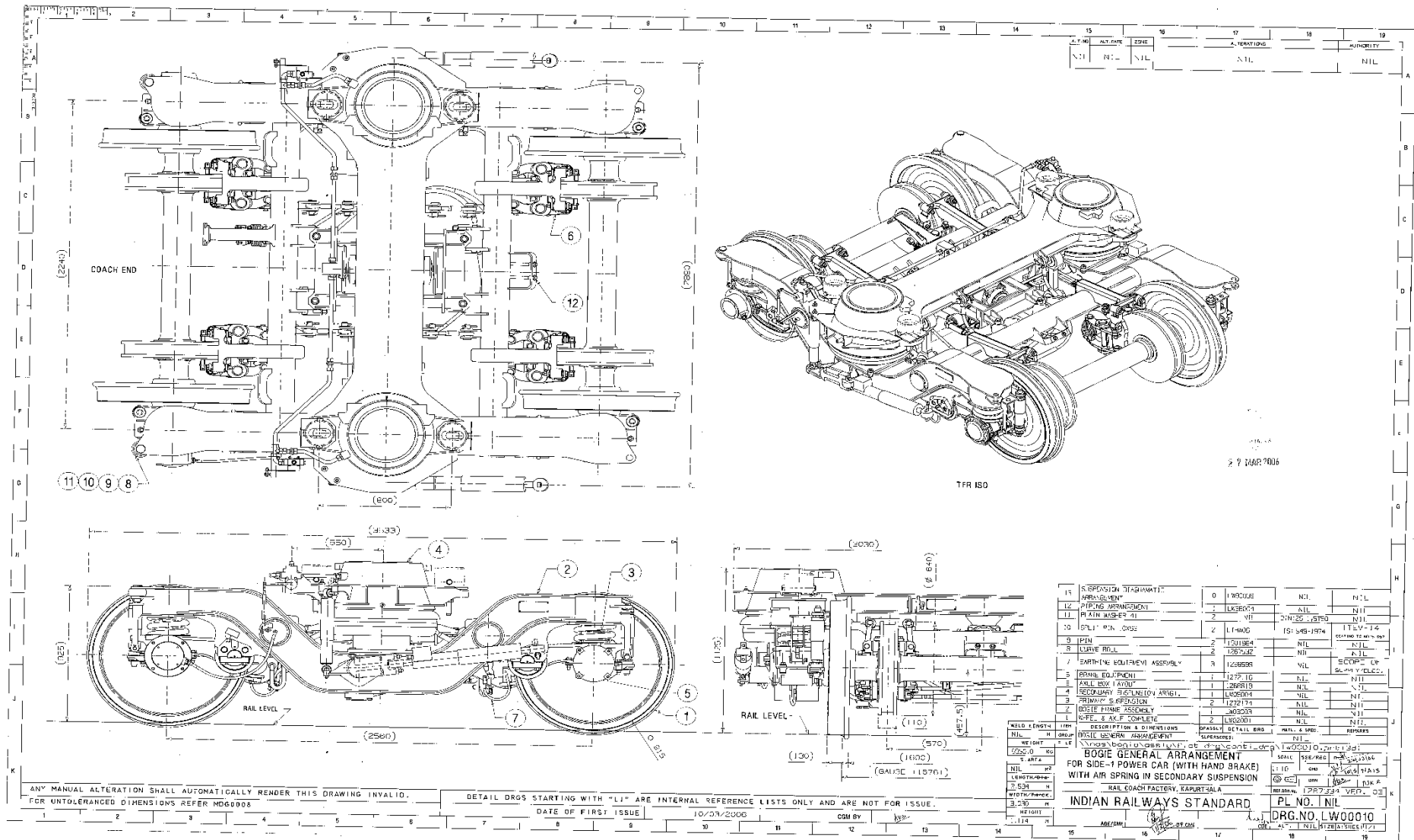

Signature of Tenderer
With Stamp

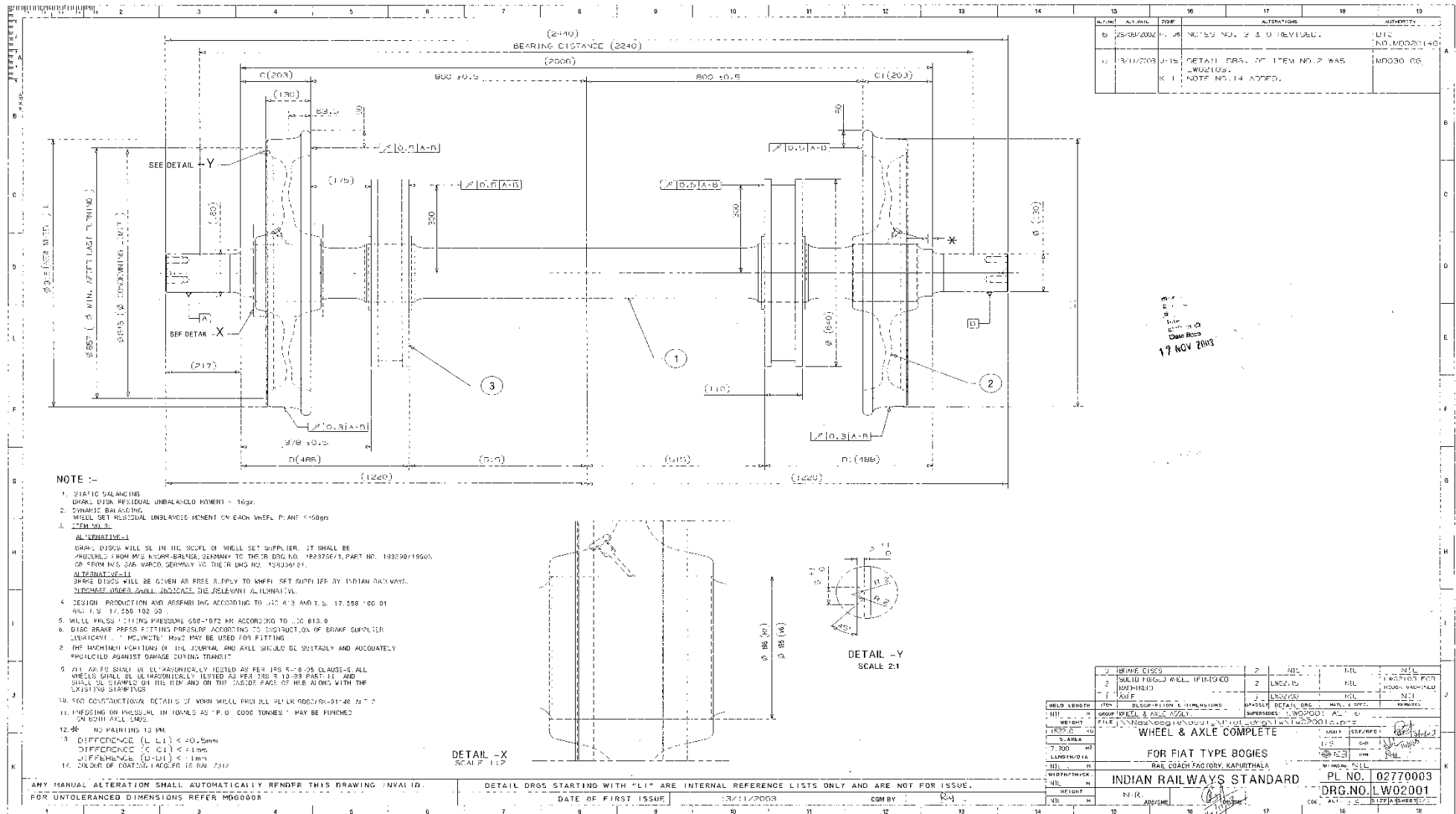

REV.	DATE	BY	DESCRIPTION
1	25/08/2008	J.S.	NOTES NO. 2 & 3 REVISED.
2	21/11/2008	J.S.	DETAIL Dwg. of ITEM NO. 2 WAS LW02102.
3			NOTE NO. 14 ADDED.

17 NOV 2008

- NOTE :-**
1. STATIC BALANCING DRAWN DISK RESIDUAL UNBALANCED MOMENT $\leq 10gr$.
 2. DYNAMIC BALANCING WHEEL SET RESIDUAL UNBALANCED MOMENT ON EACH WHEEL PLANT $\leq 50gr$.
 3. ITEM NO. 3.
- ALTERNATIVE - I**
DRAWN DISKS WILL BE IN THE SCOPE OF WHEEL SET SUPPLIER. IT SHALL BE ORDERED FROM M/S. KAYAR BRIDGE, GERMANY TO THEIR DRG NO. 1823756-1, PART NO. 133230/1000A OR FROM M/S. ZAG WAGCO, GERMANY TO THEIR DRG NO. 128030/01.
- ALTERNATIVE - II**
DRAWN DISKS WILL BE GIVEN AS FREE SUPPLY TO WHEEL SET SUPPLIER BY INDIAN RAILWAYS. PURCHASE ORDER SHALL INDICATE THE RELEVANT ALTERNATIVE.
4. DESIGN, PRODUCTION AND ASSEMBLY ACCORDING TO I.S. 813 AND I.S. 17,550-100-01 AND I.S. 17,550-102-03.
 5. WHEEL PRESS FITTING PRESSURE 650-1075 MP ACCORDING TO I.S. 813-0.
 6. DISC BRAKE PRESS FITTING PRESSURE ACCORDING TO INSTRUCTIONS OF DRAWN SUPPLIER. LUBRICANT 'MOLYKOTE' MUST BE USED FOR FITTING.
 7. THE MOUNTING PORTIONS OF THE JOURNAL AND AXLE SHOULD BE SUITABLY AND ADEQUATELY PROTECTED AGAINST DAMAGE DURING TRANSPORT.
 8. ALL AXLES SHALL BE ULTRASONICALLY TESTED AS PER IS 5-10-25 CLAUSE-6. ALL WHEELS SHALL BE IMPROVEDLY TESTED AS PER IS 5-10-25 PART II, AND SHALL BE STAMPED ON THE RIB AND ON THE OPOSITE FACE OF THE RIB ALONG WITH THE EXISTING STAMPING.
 9. FOR CONSTRUCTIONAL DETAILS OF WHEEL PRESS SEE I.R. 005/2008-01-16 PART 2.
 10. FITTING OF JOURNAL IN AXLES AS 'P.O. COGS TONES' MAY BE PUNCHED ON BOTH AXLE ENDS.
 11. NO PAINTING IS PM.
 12. DIFFERENCE (L-L1) $\leq 0.5mm$
DIFFERENCE (C-C1) $\leq 1mm$
DIFFERENCE (D-D1) $\leq 1mm$
 13. COLOUR OF COATING LARGR IS RAJ 7312

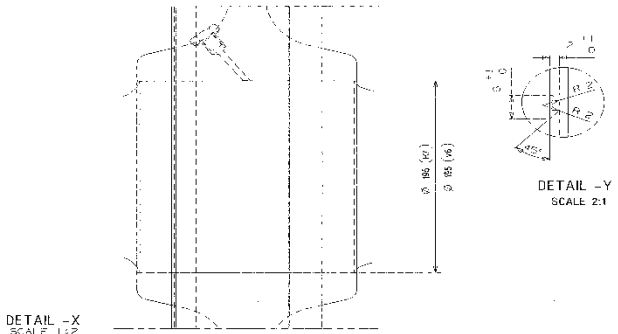

ITEM NO.	DESCRIPTION	QTY	UNIT	REMARKS
1	WHEEL & AXLE COMPLETE	2	NIL	
2	SOLID FORGED WHEEL (IF-19) CO	2	LW02102	
3	AXLE	2	LW02102	

WHEEL & AXLE COMPLETE

FOR PIAT TYPE BOGIES
RAIL COACH FACTORY, KANURITHALA

INDIAN RAILWAYS STANDARD

PL NO. 02770003
DRG. NO. LW02001

DATE OF FIRST ISSUE: 13/11/2008

Signature of Tenderer
With Stamp

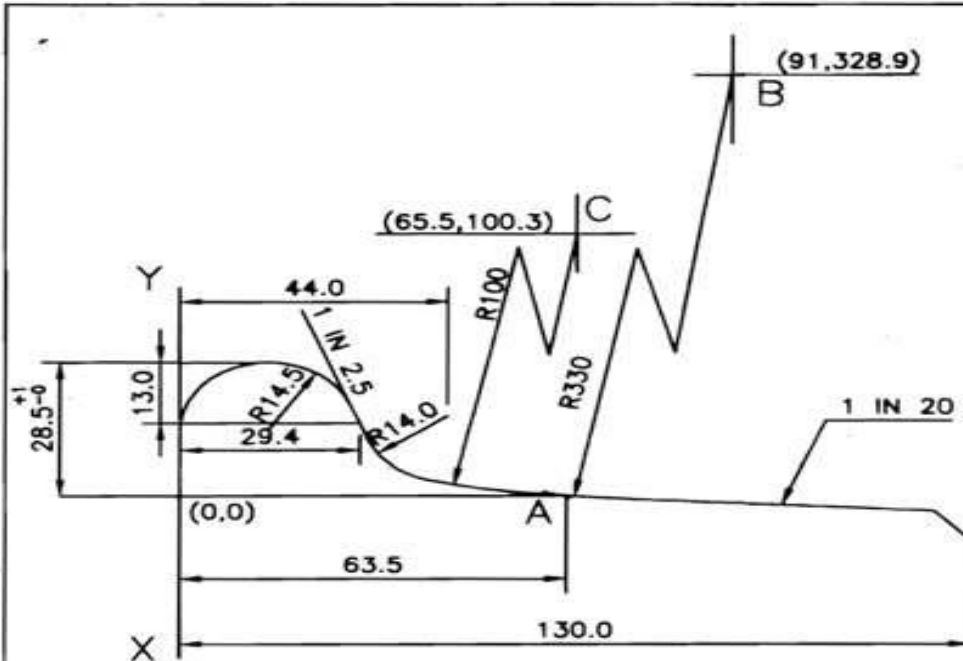

PROCEDURE OF DRAWING:-

1. DRAW A VERTICAL LINE X-Y.
2. DRAW SEMI-CIRCLE OF 14.5R TANGENTIAL TO LINE X-Y.
3. DRAW LINE 1:2.5 TANGENTIALLY TO 14.5R SEMI-CIRCLE.
4. DRAW A HORIZONTAL LINE AT 28.5mm FROM THE TOP OF THE FLANGE. AND LOCATE Pt. 'A' AT 63.5mm FROM THE LINE X-Y.
5. FROM Pt. A LOCATE CENTRE 'B' OF ARC OF 330R ON A VERTICAL LINE AT 91mm FROM X-Y.
6. DRAW ARC OF 330R FROM CENTRE 'B' LOCATE CENTRE 'C' ON VERTICAL LINE AT A HORIZONTAL DISTANCE OF 65.5mm FROM THE LINE X-Y SUCH THAT BC= (330-100) ie 230mm.
7. DRAW ARC OF 100R WITH CENTRE AS 'C'.
8. DRAW ARC OF RADIUS 14mm TANGENTIALLY TO 100R ARC AND LINE 1:2.5.
9. DRAW LINE 1:20 TANGENTIALLY TO 330R ARC.
10. DRAW A VERTICAL LINE AT A DISTANCE OF 130mm FROM THE FLANGE END.

NOTE:

CO-ORDINATES OF POINTS B & C ARE BASED ON NOMINAL DIMENSION OF 28.5mm.

ALT.	AUTH.	DESCRIPTION	DATE
③	SS/24/04	DIMENSION 73.7 DELETED	9/04
②	J.S. CO/3/94	REVISED & REDRAWN	3/94
①	J.S. CO/7/92	CO-ORDINATES OF ARCS SHOWN	3/92

SUPERSEDED BY:	
SUPERSEDES:	
SCALE	P
1:1	C
	D G.V.RAMAN
	T
	J.S.
B.G.	R.D.S.O. (C)

WORN WHEEL PROFILE

SKETCH-91146

For Service Contracts, Indian Railways follows the document titled

“General Conditions of Contract for Services”

This document is applicable to the present tender and may be downloaded by using the following link and navigation chart

<http://www.indianrailways.gov.in/railwayboard/>



About Indian Railways



Railway Board Directorates



Transformation Cell



Circulars



General Conditions of Contract for Service

http://www.indianrailways.gov.in/railwayboard/uploads/directorate/Transformation_Cell/Circulars/GCCS_R.pdf